

Retarder Proofer Cabinets

for viennese pastry

■ AFV range appliances are retarder proofer cabinets for viennese pastry, designed to receive 400x600 trays or grids

■ The AFV range consists of :

2 models of one door compartment : **AFV 46** and **68**

2 models of two doors compartments : **AFV 46 2C** and **AFV 68 2C**

2 models of one compartment with 5 swinging doors : **AFVP 46** and **68**

■ ICIP = 1 Compartment - 1 Door

I C5P = 1 Compartment - 5 Swinging doors

2C2P = 2 Compartments - 2 Doors



■ In the standard version, each model is delivered without moisture, and can be equipped with a humidity generator with an electronic probe (+ H).

■ Each model has swinging doors in the front face

■ Panels insulated with polyurethan foam 42kg / m³, high pressure, 60mm thickness, food grade PVC coating (delivered fully assembled, dismantled on request)



CFI

Le froid maîtrisé

TECHNICAL DATAS

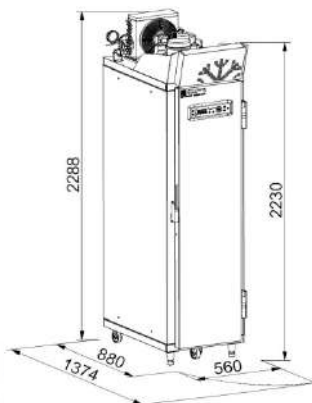

AFV 46 1CIP

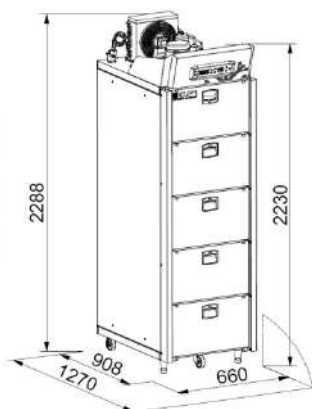

AFV 46 1C5P

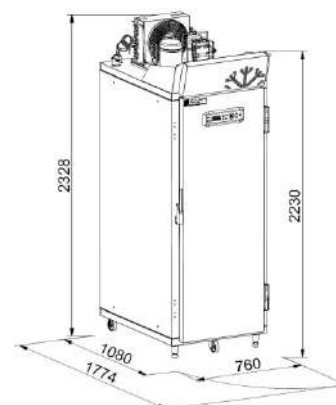

AFV 68 1CIP

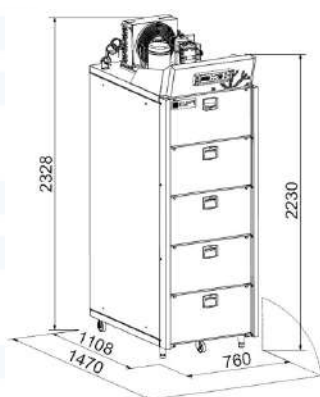

AFV 68 1C5P

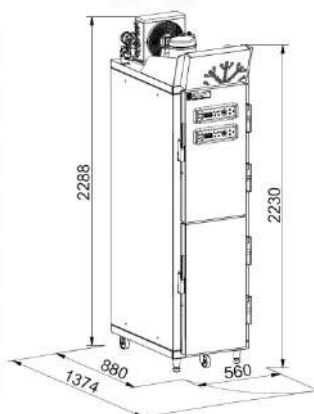

AFV 46 2C2P

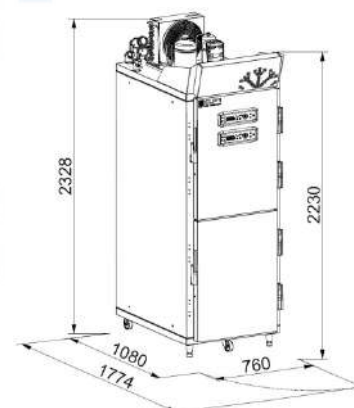

AFV 68 2C2P

	AFV 46 1CIP	AFV 46 1C5P	AFV 68 1CIP	AFV 68 1C5P	AFV 46 2C2P	AFV 68 2C2P
Size of supports	400 x 600	400 x 600	400 x 600	400 x 600	400 x 600	400 x 600
Support entry direction	400	400	600	600	400	600
N° of supports per level	1	1	2	2	1	2
Total n° of supports	24	21	48	42	20	40
N° of doors	1	5	1	5	2	2
N° of levels	24	21	24	21	2 x 10	2 x 10
Spacing out of levels	63 mm	63 mm	63 mm	63 mm	63 mm	63 mm
Adjustable every	21 mm	21 mm	21 mm	21 mm	21 mm	21 mm
Level depth	600	600	800	800	600	800
Refrigerating unit	1/3 CV	1/3 CV	7/8 CV	7/8 CV	1/3 CV	7/8 CV
Refrigerating capacity at -10°C	0,6 KW	0,6 KW	1,3 KW	1,3 KW	0,6 KW	1,3 KW
Fluid	R404A	R404A	R404A	R404A	R404A	R404A
Voltage	220-240V ~IPH+N+T					
Frequency	50 HZ	50 HZ	50 HZ	50 HZ	50 HZ	50 HZ
Connecting electrical power	0,9 KW	0,9 KW	1,3 KW	1,3 KW	1,6 KW	1,6 KW
Connection	5 A	5 A	6 A	6 A	8 A	8 A